

ACTUAL FLANGE WIDTH SETTING (IN)	4.880	6.700	6.900	8.700	9.882	11.800	13.780	15.750	16.732	17.717	18.701	19.700
MINIMUM HEADROOM DIMENSION "A" (IN)	57.48	57.48	57.40	56.69	56.24	55.51	55.51	55.51	56.59	57.67	58.75	59.84

FLANGE ADJUSTMENT RANGES
4.880" - 6.700"
6.701 - 8.700"
8.701" - 11.800"
11.801" - 15.750"
15.751" - 19.700"

DIMENSIONAL DATA	
B	48.27 INCH
C	27.22 INCH
D*	30.91 INCH
E*	38.46 INCH
Q	24.47 INCH
W*	30.26 INCH
WTD	7.87 INCH
WB	60.83 INCH
H	74.06 INCH
H1	6.61 INCH
HE	8.70 INCH
XB	1.46 INCH
AP	19.17 INCH
AQ	15.31 INCH

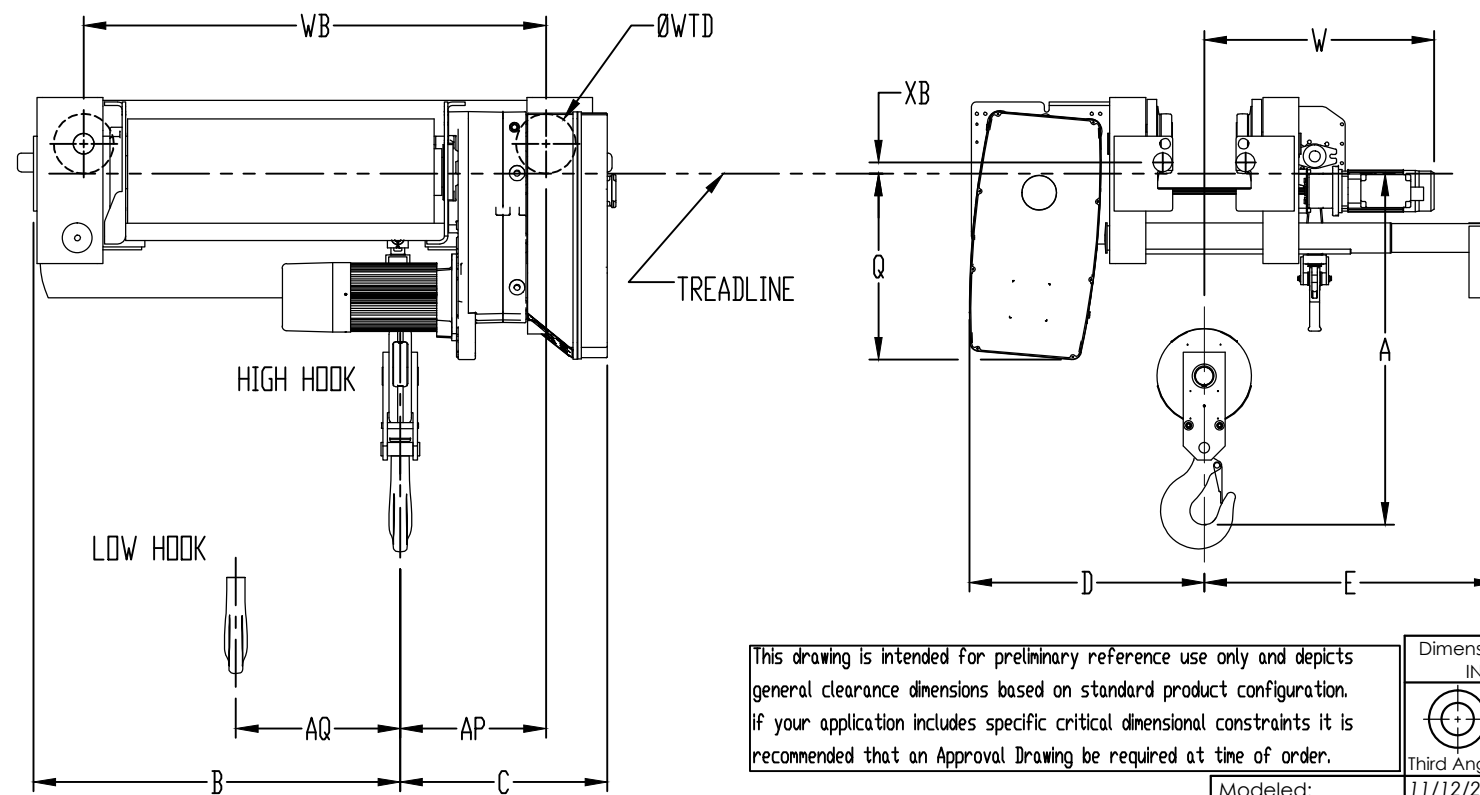
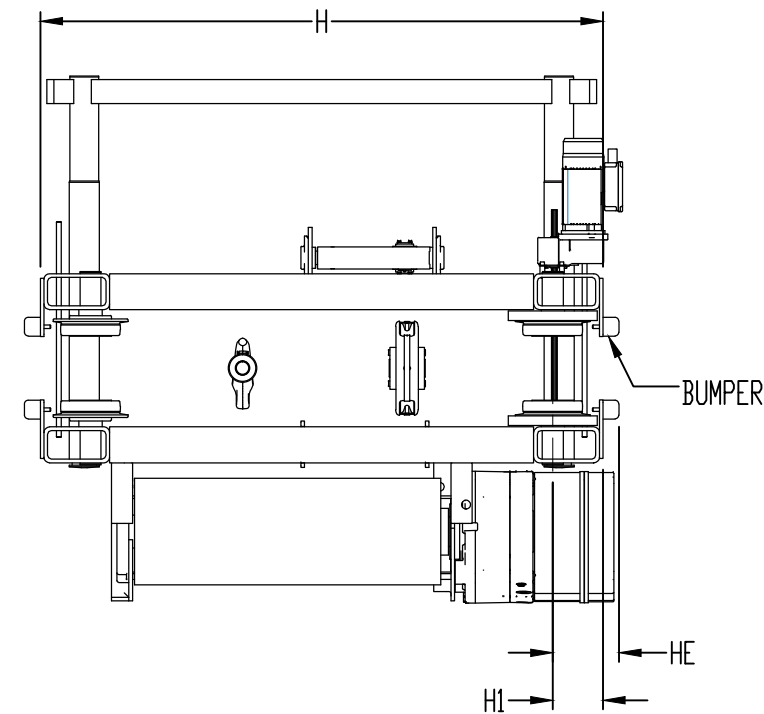

TECHNICAL DATA	
HOIST PLATFORM	GN WIRE ROPE HOIST
HOIST MODEL NUMBER	YKD-L07-093S225-2
RATED LIFT CAPACITY	7.5 U.S. TON
ACTUAL LIFT DISTANCE	93 FT (28.3 M)
MAXIMUM LIFTING SPEED	25 FT/MIN (7.6 M/MIN)
REEVING STYLE	2-PART SINGLE-REEVED
HOIST CONTROL TYPE	TWO-SPEED
HOIST SUSPENSION TYPE	UNDERHUNG MOTORIZED TROLLEY
TROLLEY TRAVERSE SPEED	80 FT/MIN (24.38 M/MIN)
TROLLEY CONTROL TYPE	TWO-SPEED
TROLLEY BUMPERS	INCLUDED
HOIST DUTY CLASSIFICATION	H4
OPERATING VOLTAGE	460V/3PH/60Hz
CONTROL VOLTAGE	120VAC
HOIST MOTOR (MAIN) HP	14.8
TROLLEY MOTOR HP	0.6
TROLLEY MOTOR QTY	1
BASE WEIGHT OF HOIST (LBS)	3307

NOTE:

* DIMENSIONS D, E, AND W ARE SHOWN FOR A BEAM FLANGE WIDTH 8.00 INCHES. THESE DIMENSIONS ARE MEASURED FROM CAD MODELS AND CONSIDERED AS APPROXIMATE VALUES.

This drawing is intended for preliminary reference use only and depicts general clearance dimensions based on standard product configuration. If your application includes specific critical dimensional constraints it is recommended that an Approval Drawing be required at time of order.

Dimensional Units
INCH



Third Angle Projection

Modeled:	11/12/2018	SRCCE
Drawn:	11/12/2018	SRCCE
Approved:		
Design Authority:	-	
Original project:	-	
Original Scale:	1:24	

2-SPEED

Description:
CLEARANCE DIAGRAM
7.5 TON 93 FT LIFT S2 REEVING 25 FT/MIN

Format	Number:	Sheet
B	YKD-L07-093S225-2	1

ECN	Rev.	Description of change	Date	By
-	-	-	-	-
-	-	-	-	-
-	-	-	-	-

ACTUAL FLANGE WIDTH SETTING (IN)	4.880	6.700	6.900	8.700	9.882	11.800	13.780	15.750	16.732	17.717	18.701	19.700
MINIMUM HEADROOM DIMENSION "A" (IN)	57.48	57.48	57.40	56.69	56.24	55.51	55.51	55.51	56.59	57.67	58.75	59.84

FLANGE ADJUSTMENT RANGES
4.880' - 6.700'
6.701 - 8.700'
8.701' - 11.800'
11.801' - 15.750'
15.751' - 19.700'

TECHNICAL DATA	
HOIST PLATFORM	GN WIRE ROPE HOIST
HOIST MODEL NUMBER	YKD-L07-093S225-V
RATED LIFT CAPACITY	7.5 U.S. TON
ACTUAL LIFT DISTANCE	93 FT (28.3 M)
MAXIMUM LIFTING SPEED	25 FT/MIN (7.6 M/MIN)
REEVING STYLE	2-PART SINGLE-REEVED
HOIST CONTROL TYPE	VARIABLE SPEED
HOIST SUSPENSION TYPE	UNDERHUNG MOTORIZED TROLLEY
TROLLEY TRAVERSE SPEED	80 FT/MIN (24.38 M/MIN)
TROLLEY CONTROL TYPE	TWO-SPEED
TROLLEY BUMPERS	INCLUDED
HOIST DUTY CLASSIFICATION	H4
OPERATING VOLTAGE	460V/3PH/60Hz
CONTROL VOLTAGE	120VAC
HOIST MOTOR (MAIN) HP	14.8
TROLLEY MOTOR HP	0.6
TROLLEY MOTOR QTY	1
BASE WEIGHT OF HOIST (LBS)	3307

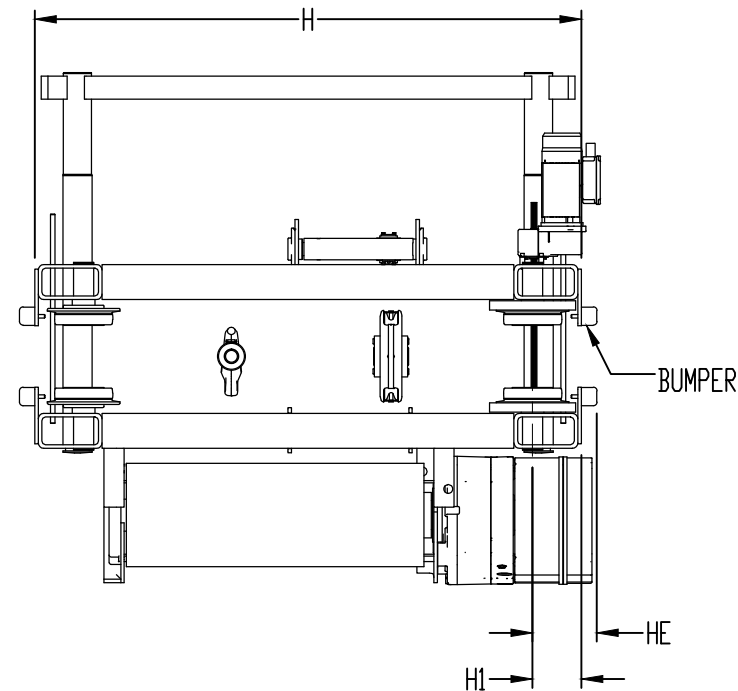

DIMENSIONAL DATA	
B	48.27 INCH
C	27.22 INCH
D*	30.91 INCH
E*	37.99 INCH
E1*	48.43 INCH
Q	24.47 INCH
W*	30.26 INCH
WTD	7.87 INCH
WB	60.83 INCH
H	74.06 INCH
H1	6.61 INCH
HE	8.70 INCH
XB	1.46 INCH
AP	19.17 INCH
AQ	15.31 INCH

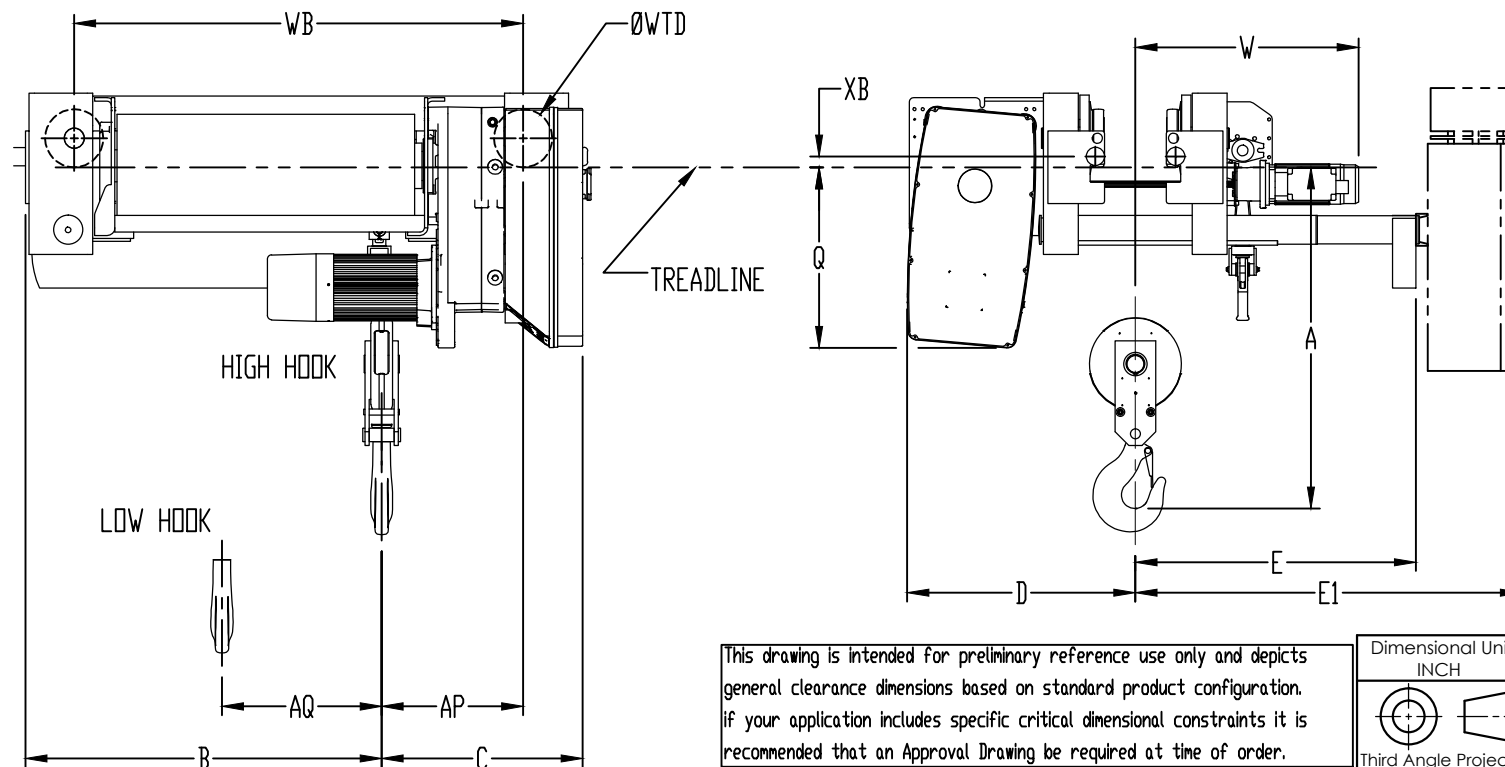

This drawing is intended for preliminary reference use only and depicts general clearance dimensions based on standard product configuration. If your application includes specific critical dimensional constraints it is recommended that an Approval Drawing be required at time of order.

Dimensional Units
INCH
Third Angle Projection

Modeled:	11/19/2018	SRCCE
Drawn:	11/19/2018	SRCCE
Approved:		
Design Authority:		
Original project:		
Original Scale:	1:24	

VARIABLE SPEED

Description:
CLEARANCE DIAGRAM
7.5 TON 93 FT LIFT S2 REEVING 25 FT/MIN

NOTE:

* DIMENSIONS D, E, E1 AND W ARE SHOWN FOR A BEAM FLANGE WIDTH 8.00 INCHES. THESE DIMENSIONS ARE MEASURED FROM CAD MODELS AND CONSIDERED AS APPROXIMATE VALUES.

ECN	Rev.	Description of change	Date	By
-	-	-	-	-
-	-	-	-	-
-	-	-	-	-

Format: **B** Number: **YKD-L07-093S225-V** Sheet: **2**